

 **EMBRAER**

kc-390.com



KC-390
MILLENNIUM

UNBEATABLE COMBINATION

 **EMBRAER**

KC-390 MILLENNIUM

UNBEATABLE COMBINATION

The new generation military multi-mission transport aircraft KC-390 Millennium is the answer to the 21st-century demands, with unrivaled mobility and operational flexibility in a single platform.

KC-390 Millennium provides optimal fleet performance, generated by a cost-effective combination of high availability and productivity.

KC-390 Millennium also incorporates the latest communication system providing ultimate digital situation awareness and interoperability with other platforms and allies.

- > RAPID RECONFIGURATION AND THE LATEST TECHNOLOGY
- > OPERATIONAL EFFICIENCY AND LOW LIFE-CYCLE COSTS
- > SPEED IN THE AIR AND FASTER TURNAROUNDS

MISSION MODULES

ONE AIRCRAFT, MANY CAPABILITIES

- AERIAL ASSAULT
- AERIAL FIREFIGHTING
- AERIAL RESUPPLY
- SEARCH AND RESCUE
- SPECIAL OPERATIONS
- HUMANITARIAN AID
- MEDICAL EVACUATION
- AIR-TO-AIR REFUELING

ALL WEATHER
Hot Weather, High Altitude and Cold Weather operations.

DUAL CERTIFICATION
Combining the efforts of both civil and military airworthiness authorities.

DAMAGE TOLERANT DESIGN
Modern structural design. Strong and durable airframe.

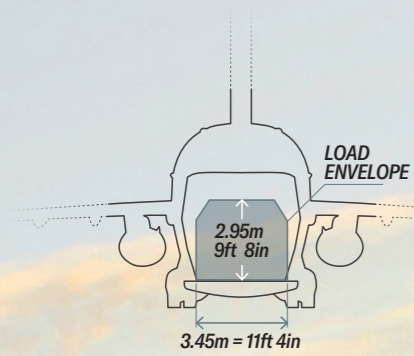
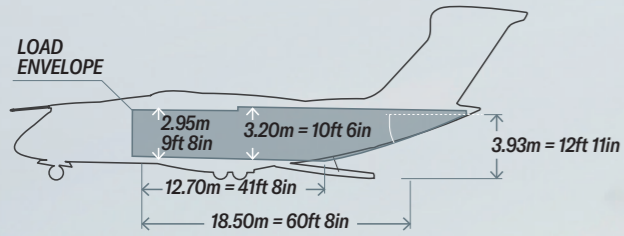
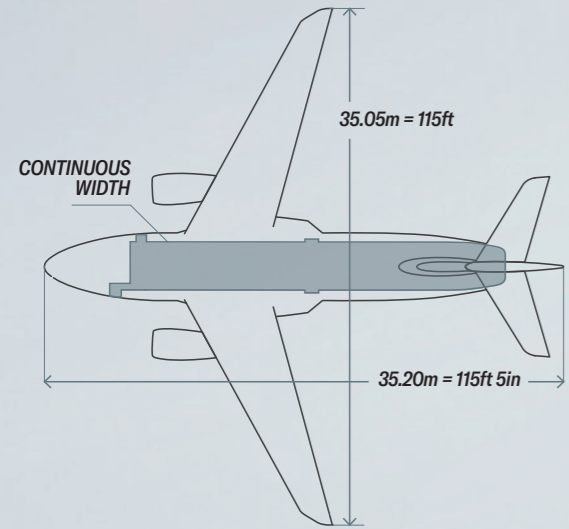

NO SCHEDULED AIRFRAME DEPOT LEVEL MAINTENANCE

Routine check:
Every 14 days of operation → ~4 man-hours

Intermediate checks:
600 FH or 12 months → ~12 days

Basic checks:
60 months → ~25 to 40 days

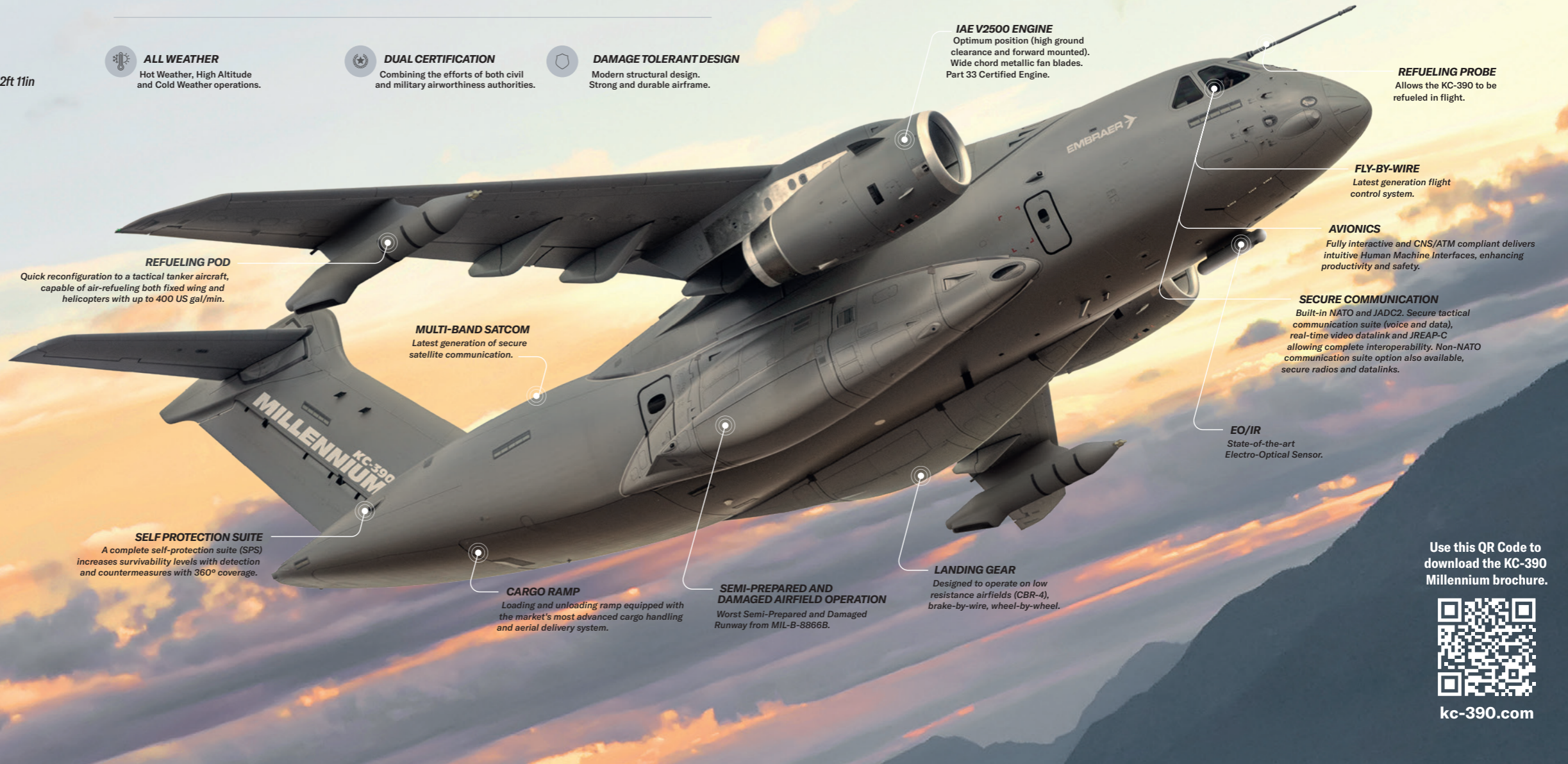

REFUELING POD
Quick reconfiguration to a tactical tanker aircraft, capable of air-refueling both fixed wing and helicopters with up to 400 US gal/min.

MULTI-BAND SATCOM
Latest generation of secure satellite communication.

SELF PROTECTION SUITE
A complete self-protection suite (SPS) increases survivability levels with detection and countermeasures with 360° coverage.

CARGO RAMP
Loading and unloading ramp equipped with the market's most advanced cargo handling and aerial delivery system.

SEMI-PREPARED AND DAMAGED AIRFIELD OPERATION
Worst Semi-Prepared and Damaged Runway from MIL-B-8866B.

LANDING GEAR
Designed to operate on low resistance airfields (CBR-4), brake-by-wire, wheel-by-wheel.

IAE V2500 ENGINE
Optimum position (high ground clearance and forward mounted). Wide chord metallic fan blades. Part 33 Certified Engine.

REFUELING PROBE
Allows the KC-390 to be refueled in flight.

FLY-BY-WIRE
Latest generation flight control system.

AVIONICS
Fully interactive and CNS/ATM compliant delivers intuitive Human Machine Interfaces, enhancing productivity and safety.

SECURE COMMUNICATION
Built-in NATO and JADC2. Secure tactical communication suite (voice and data), real-time video datalink and JREAP-C allowing complete interoperability. Non-NATO communication suite option also available, secure radios and datalinks.

EO/IR
State-of-the-art Electro-Optical Sensor.



THE MOST COMPREHENSIVE FLEXIBILITY
KC-390 is capable of transporting a maximum of 50,706 lb (23,000 kg) of distributed loads and a maximum concentrated load of 57,320 lb (26,000 kg).



Use this QR Code to download the KC-390 Millennium brochure.



kc-390.com

